

# Anchor load cell KN

Model AU, AI and VW

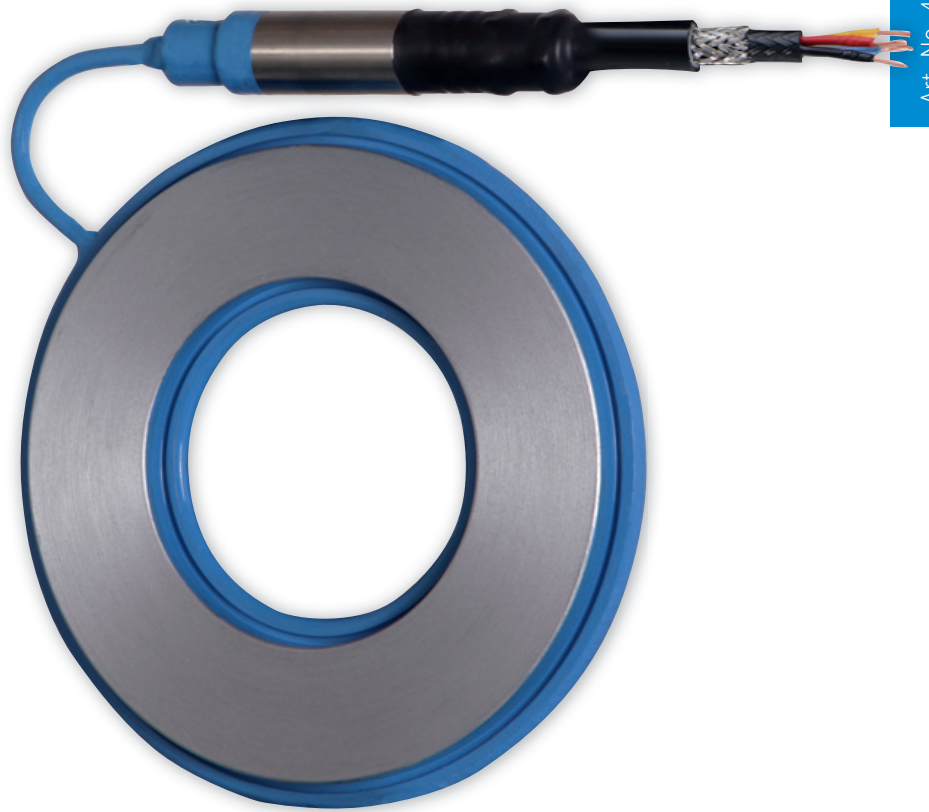

Art.-No. 41.00

The GLÖTZL anchor load cell with electronic transducer comprises a define area sensor pad made up of two flexurally stiff discs that are moveable through annular grooves around their circumference. The pressure chamber is filled with hydraulic fluid that is connected to a pressure sensor.

This combination allows voltage to be converted into a pressure display that in turn can be converted via the effective surface, into a value of load. The small volume of hydraulic fluid within a closed chamber together with the defined geometry of the sensor itself allows a highly accurate measurement to be made with minimum temperature drift.

The values listed in this brochure are oriented upon to the most usual strand and rod anchor systems. Individual adjustments can also be made at any time and at short notice. Should you so request, the dimensions of the load cells can be recalculated so that they correspond with the requirements of their installation positions, the necessary measured variables and the anchor diameter.

## TECHNICAL DATA

Model AU	
Material:	Steel S355J2 *
Power supply:	1 mA opt. 10 V DC
Output signal:	0 bis max. 250 mV
Measurement range:	250 to 5000 kN
Resolution:	1 kN
Linearity:	<0,5 % f.s.
Reproducibility:	0,01 %
Temperature range:	-30 °C to 100 °C
Temperature error:	<0,1 % °C f.s.
Protection class:	IP 68

\*\*With zinc/paint coating



Model VW	
Material:	Steel S355J2 *
Output signal:	Frequenz
Measurement range:	250 to 5000 kN
Resolution:	1 kN
Linearity:	<0,5 % f.s.
Reproducibility:	0,01 %
Temperature range:	-30 °C to 100 °C
Temperature error:	<0,1 % °C f.s.
Protection class:	IP 68

\*\*With zinc/paint coating



Model AI	
Material:	Steel S355J2 *
Versorgung:	10 to 30 V DC
Output signal:	4 to max. 20 mA
Measurement range:	250 to 5000 kN
Resolution:	1 kN
Linearity:	<0,5 % f.s.
Reproducibility:	0,01 %
Temperature range:	-30 °C to 100 °C
Temperature error:	<0,1 % °C f.s.
Protection class:	IP 68

\*\*With zinc/paint coating



## Benefits

- Hydraulic principle
- Defined force application surface
- Easy installation
- Highly robust design
- Very low temperature sensitivity
- Low overall height
- Insensitive to eccentric loading
- Comparatively low weight
- Direct display of load

## AU, AI AND VW-TYPE

With electric remote control

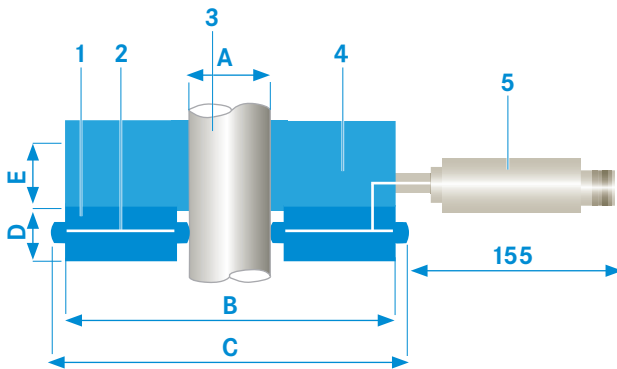

Fig.: DC2 Controller

### Recording measurement values

Expanded digitalisation is possible using the type DC2 digital encoder. This allows the economic installation of digital measurement devices in series and can be fitted with an additional temperature sensor. The cost of cable sets and cable routing work is therefore substantially reduced. Compensation is possible at the measurement value logging stage and additional linearisation can be configured in order to improve accuracy.

### SYSTEM AND DESIGN

1. Piston pad
2. Hydraulic fluid
3. Anchor
4. Distribution plate
5. Electr. pressure transducer

### Distribution plates

In order to ensure that the load are introduced to the sensor across the whole of its surface area we offer distribution plates of various designs. We are able to provide special solutions on request.

Distribution plates are suitable for extending the top and bottom areas of an anchor load sensor. A distribution plate is included in the standard scope of delivery.

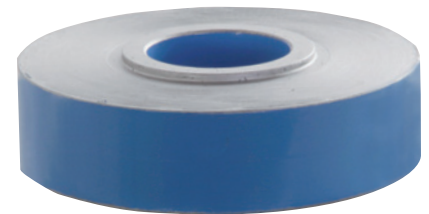

Fig.: Distribution plate

Type KN AU, AI o. VW	Load (kN)		Dimensions (mm)					Weight (kg)	
	nom	max	A	B	C	D	E	Cell	Cell + Distribution plate
KN 250 A35	250	300	35	123	144	30	27	3,5	5,8
KN 250 A50	250	300	50	133	155	30	37	3,5	6,6
KN 500 A50	500	600	50	144	165	30	37	4,5	8,2
KN 500 A60	500	600	60	152	172	30	37	4,5	8,5
KN 500 A75	500	600	75	157	179	30	37	4,5	8,4
KN 500 A90	500	600	90	165	187	30	37	4,5	8,4
KN 500 A105	500	600	105	176	198	30	37	4,5	8,6
KN 750 A50	750	900	50	144	165	30	37	4,5	8,2
KN 750 A60	750	900	60	159	172	30	37	4,5	8,5
KN 750 A75	750	900	75	157	179	30	37	5,5	11,5
KN 750 A90	750	900	90	165	187	30	37	4,5	8,4
KN 750 A105	750	900	105	176	198	30	37	4,5	8,6
KN 1000 A105	1000	1200	105	219	241	30	42	7,5	16,7
KN 1000 A115	1000	1200	115	228	250	30	42	7,5	17,4
KN 1000 A135	1000	1200	135	235	257	30	47	7,5	17,8
KN 1400 A105	1400	1600	105	219	241	30	42	7,5	16,7
KN 1400 A135	1400	1600	135	235	257	30	47	7,5	17,8
KN 1400 A160	1400	1600	161	282	306	30	61	10,0	29,7
KN 2000 A135	2000	2400	135	265	287	30	61	10,0	29,4
KN 2000 A160	2000	2400	161	282	306	30	61	10,0	29,7
KN 3000 A160	3000	3600	160	336	360	41	76	21,5	61,5
KN 3000 A180	3000	3600	180	340	364	41	76	20,0	58,5
KN 5000 A160	5000	6000	160	380	406	50	81	35,5	94
KN 5000 A200	5000	6000	200	400	426	50	81	35,5	94,5

\*Extra distribution plate upon request

\*Further load ranges upon request